

TECHNICAL INFORMATION _ CAT. N. YDTB 2FNL 0000 A1900

2 FUNCTIONS DEEP TUBE SPRAYBALL A19

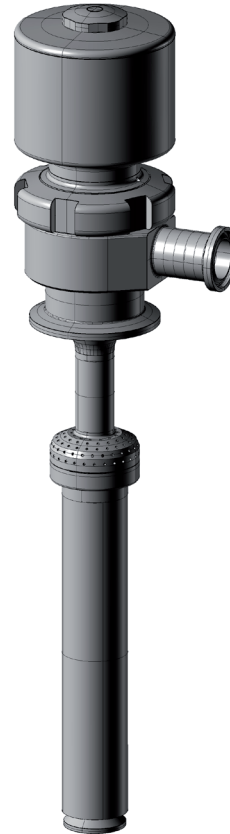
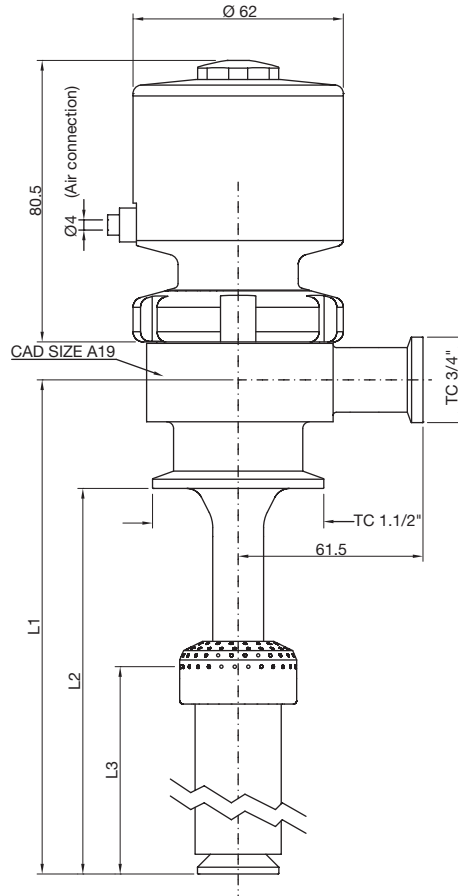

Clean and Aseptic Valves of CAD Product Line have simple and safe design, with their full drainability, without asymptotic seal and dead leg, are offering fast cleanability and sterilization practices. They are designed to fulfil stringent demands of CIP-SIP and Production Cycles on Aseptic Processing.

2 Functions Deep Tube Sprayball A19 for SAFE areas engineered to give the best solution for the typical needs on the top of the process vessel offering the integration of a diptube with a spray ball in one tool ready to use for: filling, CIP-SIP activities. They offer also reduction of nozzles number on top vessel as additional benefit. Body shape and their internal design offer a very reliable component for Aseptic Processing Application. Standard version made with Tri-Clamp connections.

NOMINAL DIMENSION	CAD SIZE	L1	L2	L3
YDTB-2FNL-0000-A1900	A19		Tailored	

(*) US Tube ASTM® A269/270 – ASME BPE

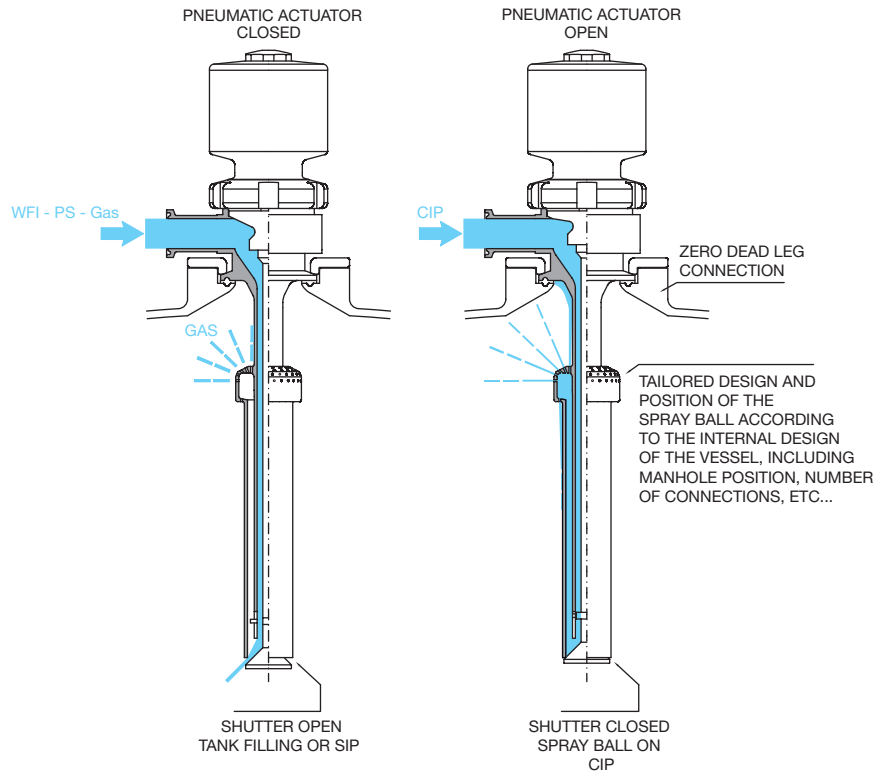
SPECIFICATION:

MATERIAL	1,4435-BN2 - Low Ferrite - Low Sulphur
-----------------	--

Design Temperature: -80 to 200 °C (-112 to 392 °F)

Application Areas: SAFE

Design Pressure, Valve Body: -1 to 10 bar (-14.5 to 145 psi)

Note: The applied actuator and diaphragm may have different design temperature and/or pressure limits. The weakest component determines the maximum design temperature and pressure limits, when they are assembled.

Surface Roughness: Internal surface (manually polished) $Ra \leq 0.3\mu m$ (16 μin)
 External surface $Ra \leq 0.5\mu m$ (20 μin)

Surface Treatment: Available also on EP version - Elettropolishing after manual polished

Labeling: Each valve body is labeled for full LOT traceability

Packaging: Valve body is sealed in plastic bags and packaged in a closed box with Operating and Maintenance bulletin, Certificate of Conformity and Materials Certification 3.1

Quality Control: Quality Assurance System guarantees the control and traceability of the product.

Rules Compliances: CAD valve are on going to be classified for PED Directive 97/23/EC and fulfill ASME BPE Standards

Orders and Information: For additional information or to place a order call your nearest Distributor or visit www.rattiinox.com

Vertical Assembly

