

TECHNICAL INFORMATION _ CAT. N. YP63 SE38 FT25 ASO25

EXTENDED POINT OF USE ON 63 VALVE BODY SO38 EXTENDED + FT25 + SO25

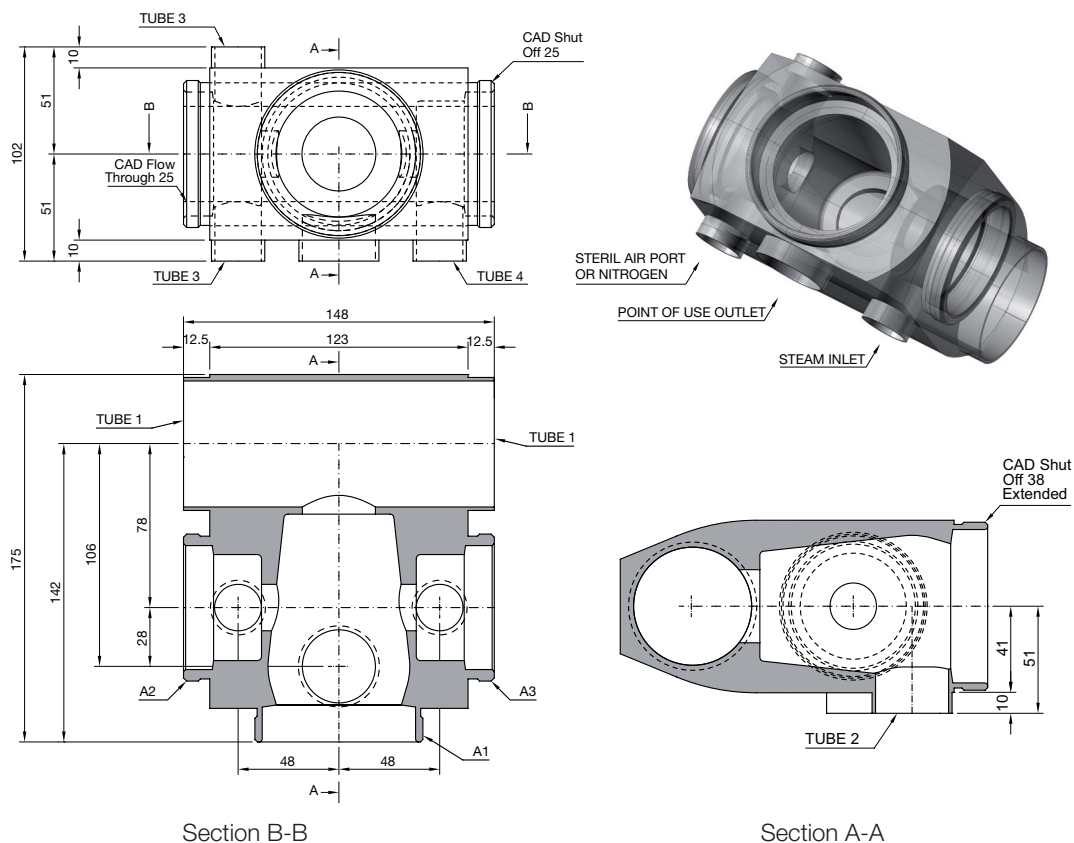

Clean and Aseptic Valves of CAD Product Line have simple and safe design, with their full drainability, without asymptotic seal and dead leg, are offering fast cleanability and sterilization practices. They are designed to fulfil stringent demands of CIP-SIP and Production Cycles on Aseptic Processing.

Extended Point of Use Assembly for SAFE areas is engineered to fulfil the demand to assembly in a block valve, WFI take off, Pure Steam, Nitrogen, and sampling valves, ready for installation, Point of Use in one tool ready to use, with Zero Dead legs, without Unused Portions and with flush flow seal. Body shape and their internal design offer a very reliable component for Aseptic processing Application. They fulfill all stringent requirements for CIP-SIP activities. Standard version are short butt weld ends but, on demand, may be delivered for orbital welding or with Tri-Clamp connections.

CODE	A1	A2	A3	TUBE 1* mm (inch)	TUBE 2* mm (inch)	TUBE 3* mm (inch)	TUBE 4* mm (inch)
YP63-SE38-FT25-ASO25	A38 Extended M80x1,5	A25 M70x1	A25 M70x1	63,50x1,65 (2,50x0,065)	38,10x1,65 (1,50x0,065)	25,40x1,65 (1,00x0,065)	25,40x1,65 (1,00x0,065)

(*) US Tube ASTM® A269/270 – ASME BPE

SPECIFICATION:

CAD VALVE POSITION		A1	A2	A3				
CAD VALVE SIZE		A38 Extended	A25	A25				
NET VOLUME⁽¹⁾	ml	216,64	32,14	32,14				

⁽¹⁾ Internal valve cavity only, for each cavity, with diaphragm on site

MATERIAL	1,4435-BN2 - Low Ferrite - Low Sulphur
-----------------	--

Design Temperature: -80 to 200 °C (-112 to 392 °F)

Application Areas: SAFE

Design Pressure, Valve Body: -1 to 10 bar (-14.5 to 145 psi)

Note: The applied actuator and diaphragm may have different design temperature and/or pressure limits. The weakest component determines the maximum design temperature and pressure limits, when they are assembled.

Surface Roughness: Internal surface (manually polished) $Ra \leq 0.3\mu\text{m}$ (16 μin)
 External surface $Ra \leq 0.5\mu\text{m}$ (20 μin)

Surface Treatment: Available also on EP version - Elettropolishing after manual polished

Labeling: Each valve body is labeled for full LOT traceability

Packaging: Valve body is sealed in plastic bags and packaged in a closed box with Operating and Maintenance bulletin, Certificate of Conformity and Materials Certification 3.1

Quality Control: Quality Assurance System guarantees the control and traceability of the product.

Rules Compliances: CAD valve are on going to be classified for PED Directive 97/23/EC and fulfill ASME BPE Standards

Options: For non-standard CAD Valve body Options, please contact us for further information.

Orders and Information: For additional information or to place a order call your nearest Distributor or visit www.rattiinox.com

Horizontal Assembly

