

TECHNICAL INFORMATION \_ CAT. N. YP50 SE38 FT25 ASO25

## EXTENDED POINT OF USE ON 50 VALVE BODY SO38 EXTENDED + FT25 + SO25

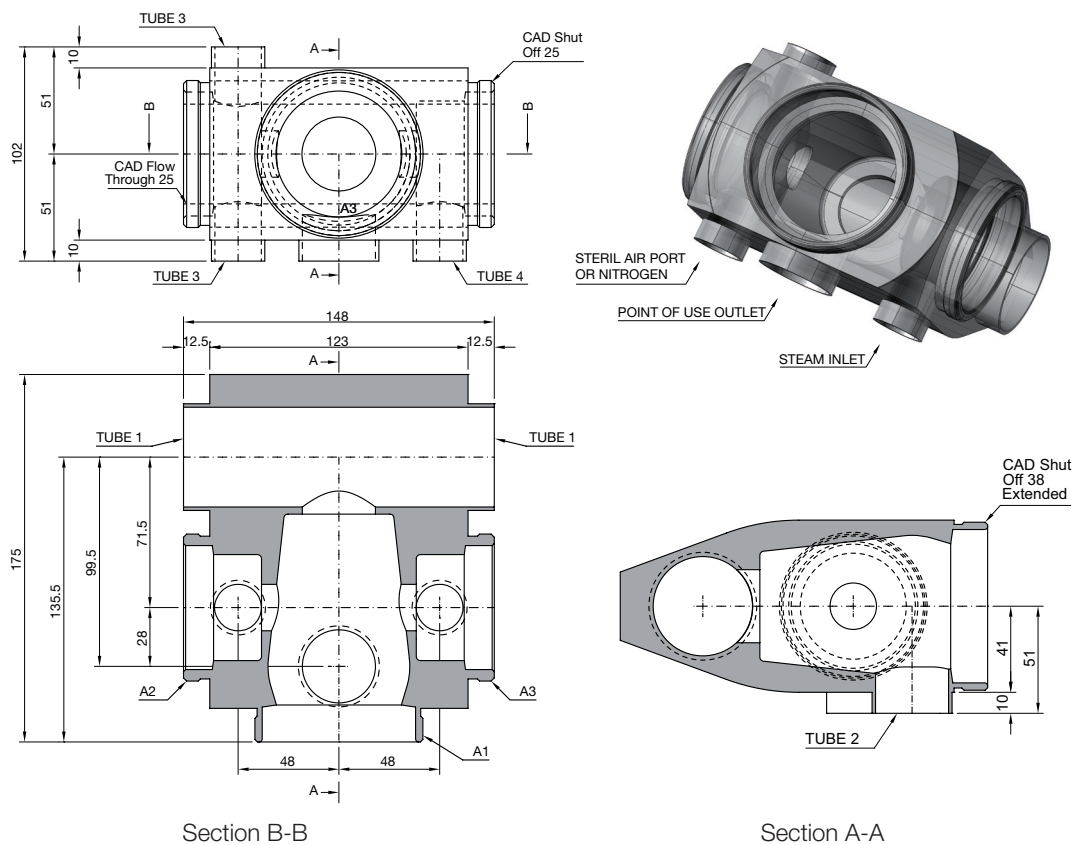

Clean and Aseptic Valves of CAD Product Line have simple and safe design, with their full drainability, without asymptotic seal and dead leg, are offering fast cleanability and sterilization practices. They are designed to fulfil stringent demands of CIP-SIP and Production Cycles on Aseptic Processing.

**Extended Point of Use Assembly** for SAFE areas is engineered to fulfil the demand to assembly in a block valve, WFI take off, Pure Steam, Nitrogen, and sampling valves, ready for installation, Point of Use in one tool ready to use, with Zero Dead legs, without Unused Portions and with flush flow seal. Body shape and their internal design offer a very reliable component for Aseptic processing Application. They fulfill all stringent requirements for CIP-SIP activities. Standard version are short butt weld ends but, on demand, may be delivered for orbital welding or with Tri-Clamp connections.

CODE	A1	A2	A3	TUBE 1* mm (inch)	TUBE 2* mm (inch)	TUBE 3* mm (inch)	TUBE 4* mm (inch)
YP50-SE38-FT25-ASO25	A38 Extended M80x1,5	A25 M70x1	A25 M70x1	50,80x1,65 (2,00x0,065)	38,10x1,65 (1,50x0,065)	25,40x1,65 (1,00x0,065)	25,40x1,65 (1,00x0,065)

(\*) US Tube ASTM® A269/270 – ASME BPE

**SPECIFICATION:**

<b>CAD VALVE POSITION</b>		A1	A2	A3				
<b>CAD VALVE SIZE</b>		A38 Extended	A25	A25				
<b>NET VOLUME<sup>(1)</sup></b>	ml	216,64	32,14	32,14				

<sup>(1)</sup> Internal valve cavity only, for each cavity, with diaphragm on site

<b>MATERIAL</b>	1,4435-BN2 - Low Ferrite - Low Sulphur
-----------------	--

**Design Temperature:** -80 to 200 °C (-112 to 392 °F)

**Application Areas:** SAFE

**Design Pressure, Valve Body:** -1 to 10 bar (-14.5 to 145 psi)

**Note:** The applied actuator and diaphragm may have different design temperature and/or pressure limits. The weakest component determines the maximum design temperature and pressure limits, when they are assembled.

**Surface Roughness:** Internal surface (manually polished)  $Ra \leq 0.3\mu m$  (16 $\mu in$ )  
External surface  $Ra \leq 0.5\mu m$  (20 $\mu in$ )

**Surface Treatment:** Available also on EP version - Elettropolishing after manual polished

**Labeling:** Each valve body is labeled for full LOT traceability

**Packaging:** Valve body is sealed in plastic bags and packaged in a closed box with Operating and Maintenance bulletin, Certificate of Conformity and Materials Certification 3.1

**Quality Control:** Quality Assurance System guarantees the control and traceability of the product.

**Rules Compliances:** CAD valve are on going to be classified for PED Directive 97/23/EC and fulfill ASME BPE Standards

**Options:** For non-standard CAD Valve body Options, please contact us for further information.

**Orders and Information:** For additional information or to place a order call your nearest Distributor or visit [www.rattiinox.com](http://www.rattiinox.com)

Horizontal Assembly

