

TECHNICAL INFORMATION \_ CAT. N. YT50 FECL 0000 A##00

## EXTENDED FLOW THROUGH 90 2" TC CONN. VALVE BODY

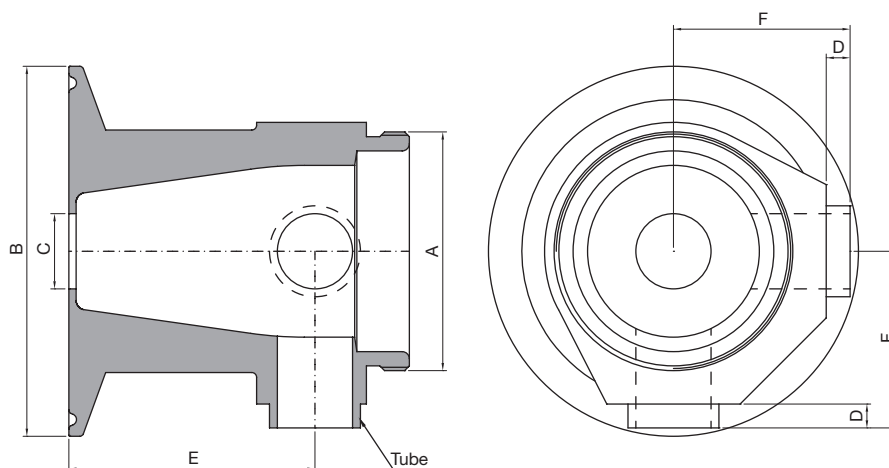

Clean and Aseptic Valves of CAD Product Line have simple and safe design, with their full drainability, without asymptotic seal and dead leg, are offering fast cleanability and sterilization practices. They are designed to fulfill stringent demands of CIP-SIP and Production Cycles on Aseptic Processing.

**YT50 - FECL - Extended Flow Through TC 2" Connectable Valves** for SAFE areas designed with a flush flow frontal inlet with the aim to feed or take off fluids or gases from process piping or vessel, when TC connection is available. Body shape and their internal design offer a very reliable component for Aseptic Processing Application. Standard version are short butt weld ends but, on demand, may be delivered for orbital welding or with Tri-Clamp connections.

CODE	A	B mm (inch)	C mm (inch)	D mm (inch)	E mm (inch)	F mm (inch)	TUBE* mm (inch)
YT50-FECL-0000-A1200	M34x1	64,00 (2,52)	9,40 (0,37)	5,00 (0,20)	26,50 (1,04)	31,00 (1,22)	12,70x1,65 (0,50x0,065)
YT50-FECL-0000-A1900	M50x1	64,00 (2,52)	15,75 (0,62)	5,00 (0,20)	51,50 (2,03)	33,00 (1,30)	19,05x1,65 (0,75x0,065)
YT50-FECL-0000-A2500	M70x1	64,00 (2,52)	22,10 (0,87)	5,00 (0,20)	54,00 (2,13)	47,00 (1,85)	25,40x1,65 (1,00x0,065)

(\*) US Tube ASTM® A269/270 – ASME BPE

**SPECIFICATION:**

<b>CAD SIZE</b>	A12	A19	A25				
-----------------	-----	-----	-----	--	--	--	--

<b>NET VOLUME<sup>(1)</sup></b>	ml	7,12	30,20	56,36			
---------------------------------	----	------	-------	-------	--	--	--

<sup>(1)</sup> Internal valve cavity only, with diaphragm on site

<b>MATERIAL</b>	1,4435-BN2 - Low Ferrite - Low Sulphur
-----------------	--

**Design Temperature:** -80 to 200 °C (-112 to 392 °F)

**Application Areas:** SAFE

**Design Pressure, Valve Body:** -1 to 10 bar (-14.5 to 145 psi)

**Note:** The applied actuator and diaphragm may have different design temperature and/or pressure limits. The weakest component determines the maximum design temperature and pressure limits, when they are assembled.

**Surface Roughness:** Internal surface (manually polished) Ra ≤ 0.3µm (16µin)  
External surface Ra ≤ 0.5µm (20µin)

**Surface Treatment:** Available also on EP version - Elettropolishing after manual polished

**Labeling:** Each valve body is labeled for full LOT traceability

**Packaging:** Valve body is sealed in plastic bags and packaged in a closed box with Operating and Maintenance bulletin, Certificate of Conformity and Materials Certification 3.1

**Quality Control:** Quality Assurance System guarantees the control and traceability of the product.

**Rules Compliances:** CAD valve are on going to be classified for PED Directive 97/23/EC and fulfill ASME BPE Standards

**Standard design:** TC connectable Shut Off bodies are available also tangential outlet Left or Right

**Options:** For non-standard CAD Valve body Options, please contact us for further information.

**Orders and Information:** For additional information or to place a order call your nearest Distributor or visit [www.rattiinox.com](http://www.rattiinox.com)

Horizontal Assembly

