

TECHNICAL INFORMATION _ CAT. N. YPRO FTCI 0000 A##00

FLOW THROUGH 180 VALVE BODY

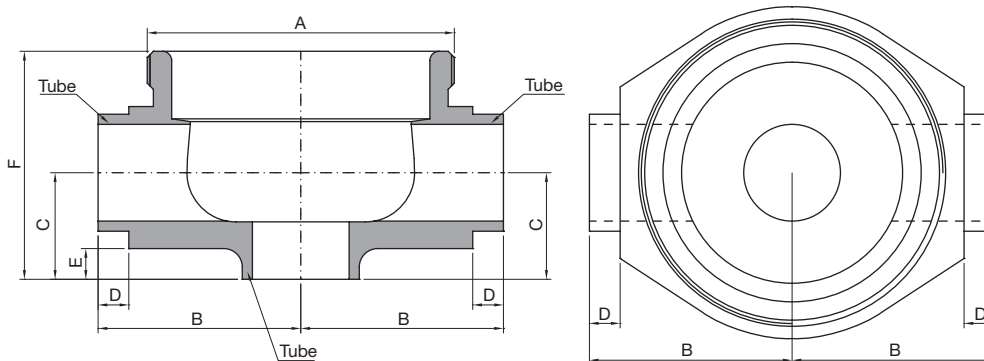

Clean and Aseptic Valves of CAD Product Line have simple and safe design, with their full drainability, without asymptotic seal and dead leg, are offering fast cleanability and sterilization practices. They are designed to fulfill stringent demands of CIP-SIP and Production Cycles on Aseptic Processing.

YPRO – FTCI - Flow Through Valves are designed to have the body integrated on process piping with the aim to feed or take off fluids or gases from the process piping. Body shape and their internal design offer a very reliable component for Aseptic Processing Application. Standard version are short butt weld ends but, on demand, may be delivered for orbital welding or with Tri-Clamp connections.

CODE	A	B mm (inch)	C mm (inch)	D mm (inch)	E mm (inch)	F mm (inch)	TUBE* mm (inch)
YPRO-FTCI-0000-A1200	M34x1	26,00 (1,02)	15,00 (0,59)	5,00 (0,20)	7,30 (0,29)	30,50 (1,20)	12,70x1,65 (0,50x0,065)
YPRO-FTCI-0000-A1900	M50x1	33,00 (1,30)	20,00 (0,79)	5,00 (0,20)	8,00 (0,31)	40,00 (1,58)	19,05x1,65 (0,75x0,065)
YPRO-FTCI-0000-A2500	M70x1	47,00 (1,85)	25,00 (0,98)	5,00 (0,20)	10,00 (0,39)	51,00 (2,01)	25,40x1,65 (1,00x0,065)
YPRO-FTCI-0000-A3800	M80x1,5	60,00 (2,36)	34,00 (1,34)	21,00 (0,83)	11,00 (0,43)	70,00 (2,76)	38,10x1,65 (1,50x0,065)
YPRO-FTCI-0000-A5000	M103x1,5	75,00 (2,95)	40,00 (1,58)	24,00 (0,95)	12,00 (0,47)	84,00 (3,31)	50,80x1,65 (2,00x0,065)
YPRO-FTCI-0000-A6300	M120x1,5	85,00 (3,35)	59,00 (2,32)	24,00 (0,95)	24,00 (0,95)	108,50 (4,27)	63,50x1,65 (2,50x0,065)
YPRO-FTCI-0000-A7600	M140x1,5	95,00 (3,74)	68,00 (2,68)	26,00 (1,02)	26,00 (1,02)	129,50 (5,10)	76,20x1,65 (3,00x0,065)

(*) US Tube ASTM® A269/270 - ASME BPE

SPECIFICATION:

CAD SIZE	A12	A19	A25	A38	A50	A63	A76	
NET VOLUME ⁽¹⁾	ml	2,86	10,23	32,14	86,89	208,58	302,03	533,33

⁽¹⁾ Internal valve cavity only, with diaphragm on site

MATERIAL	1,4435-BN2 - Low Ferrite - Low Sulphur
----------	--

Design Temperature: -80 to 200 °C (-112 to 392 °F)

Design Pressure, Valve Body: -1 to 10 bar (-14.5 to 145 psi)

Note: The applied actuator and diaphragm may have different design temperature and/or pressure limits. The weakest component determines the maximum design temperature and pressure limits, when they are assembled.

Surface Roughness: Internal surface (manually polished) $Ra \leq 0.3\mu\text{m}$ (16 μin)
 External surface $Ra \leq 0.5\mu\text{m}$ (20 μin)

Surface Treatment: Available also on EP version - Elettropolishing after manual polished

Labeling: Each valve body is labeled for full LOT traceability

Packaging: Valve body is sealed in plastic bags and packaged in a closed box with Operating and Maintenance bulletin, Certificate of Conformity and Materials Certification 3.1

Quality Control: Quality Assurance System guarantees the control and traceability of the product.

Rules Compliances: CAD valve are on going to be classified for PED Directive 97/23/EC and fulfill ASME BPE Standards

Standard design: Flow Tru bodies are available also to 90°, tangential outlet Left or Right

Options: For non-standard CAD Valve body Options, please contact us for further information.

Orders and Information: For additional information or to place a order call your nearest Distributor or visit www.rattiinox.com

Horizontal Assembly

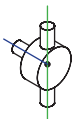

Vertical Assembly

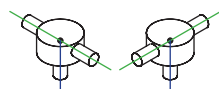

Upside-Down Assembly

